



US 20150303243A1

(19) **United States**

(12) **Patent Application Publication**

Shin et al.

(10) **Pub. No.: US 2015/0303243 A1**

(43) **Pub. Date: Oct. 22, 2015**

(54) **ORGANIC LIGHT EMITTING DISPLAY DEVICES AND METHODS OF MANUFACTURING ORGANIC LIGHT EMITTING DISPLAY DEVICES**

(52) **U.S. CL.**
CPC *H01L 27/3258* (2013.01); *H01L 27/3246* (2013.01); *H01L 51/5012* (2013.01); *H01L 51/5056* (2013.01); *H01L 51/5088* (2013.01); *H01L 51/5072* (2013.01); *H01L 51/5092* (2013.01)

(71) Applicant: **Samsung Display Co., Ltd.**,
Yongin-City (KR)

(72) Inventors: **Hyea-Weon Shin**, Yongin-City (KR);
Dong-Won Lee, Yongin-City (KR);
Young-Mok Son, Yongin-City (KR)

(57) **ABSTRACT**

(21) Appl. No.: **14/754,654**

(22) Filed: **Jun. 29, 2015**

Related U.S. Application Data

(62) Division of application No. 13/919,343, filed on Jun. 17, 2013.

Foreign Application Priority Data

Sep. 28, 2012 (KR) 10-2012-0108682

Publication Classification

(51) **Int. Cl.**
H01L 27/32 (2006.01)
H01L 51/50 (2006.01)

An organic light emitting display device is disclosed. The organic light emitting display device includes a substrate, a first electrode, a pixel defining layer, a first hydrophobic pattern, at least one charge transport layer, a second hydrophobic pattern, an organic light emitting layer and a second electrode. The substrate has a pixel region and a non pixel region surrounding the pixel region. The first electrode, the at least one charge transport layer and the organic light emitting layer are disposed on the substrate in the pixel region, while the pixel defining layer, the first hydrophobic pattern and the second hydrophobic pattern are disposed on the substrate in the non pixel region. The charge transport layer of one pixel is separated from a charge transport layer of another pixel by the first and second hydrophobic patterns to prevent crosstalk phenomenon.

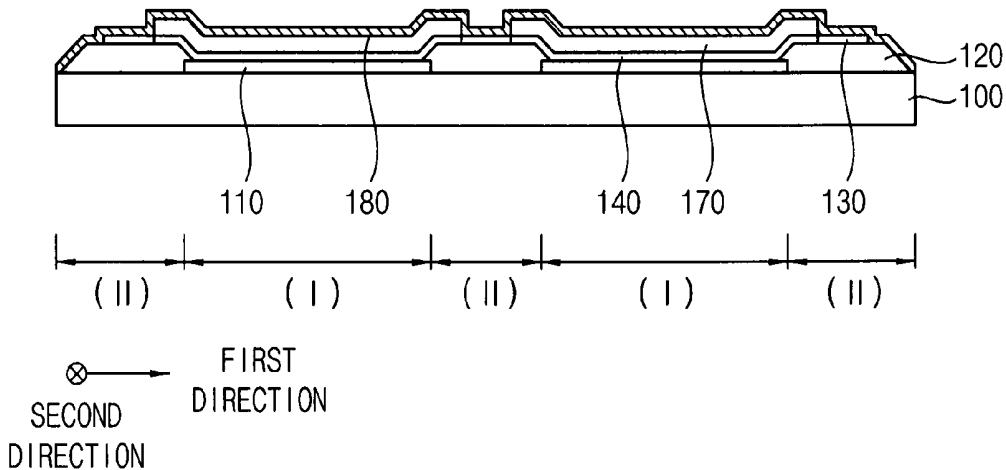

FIG. 1

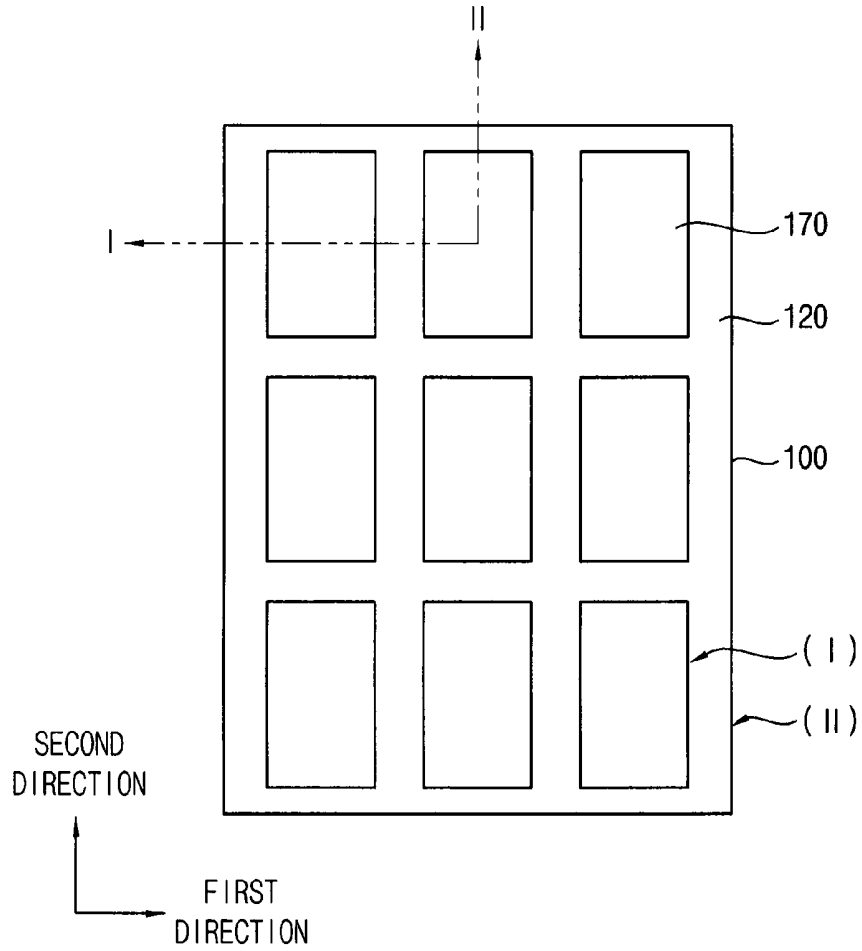

FIG. 2

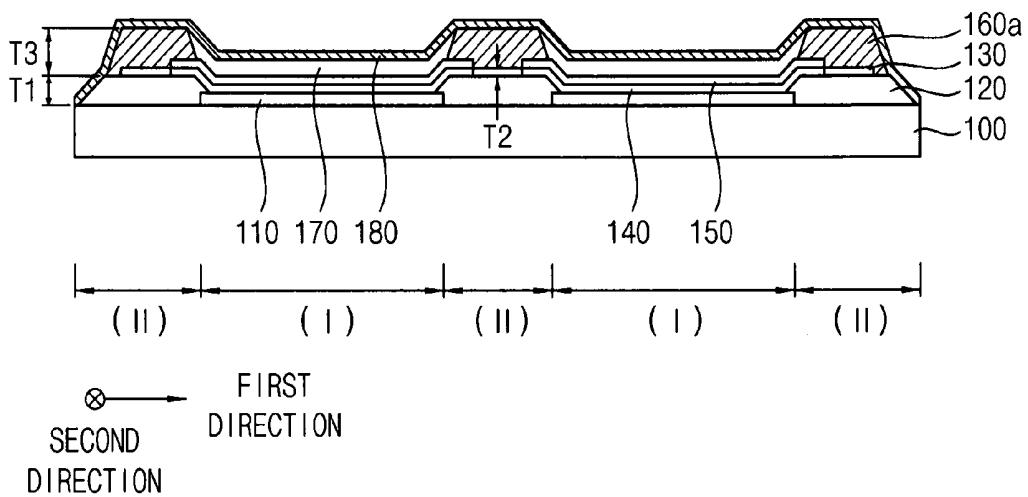

FIG. 3

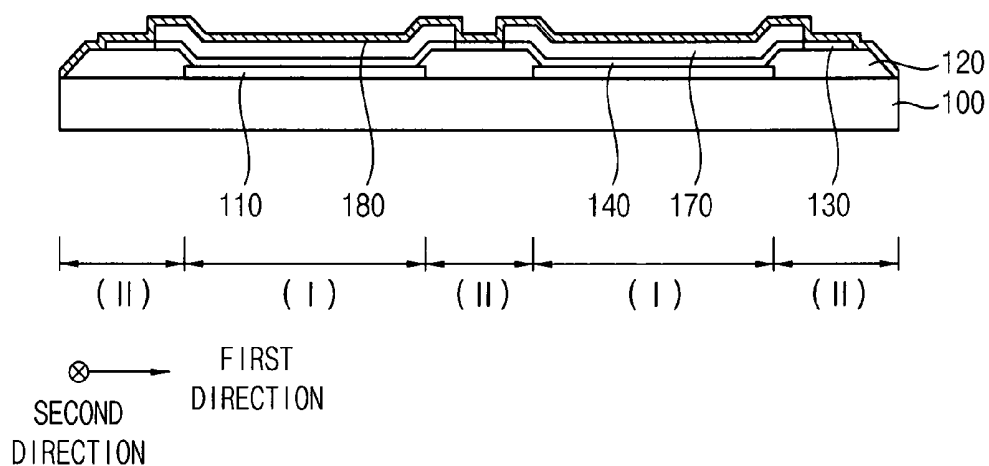

FIG. 4

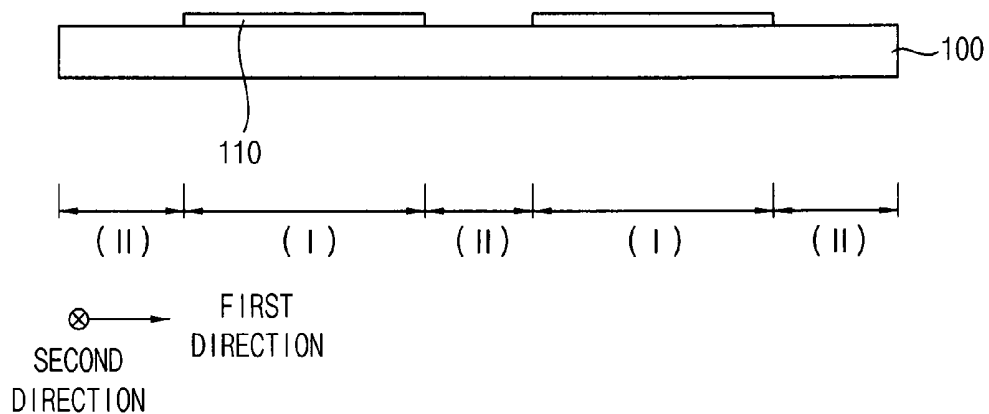

FIG. 5

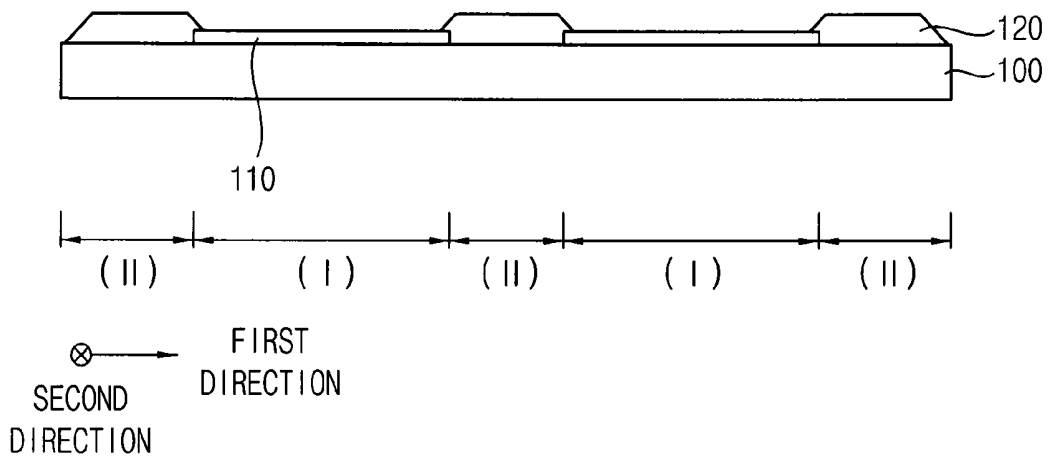

FIG. 6

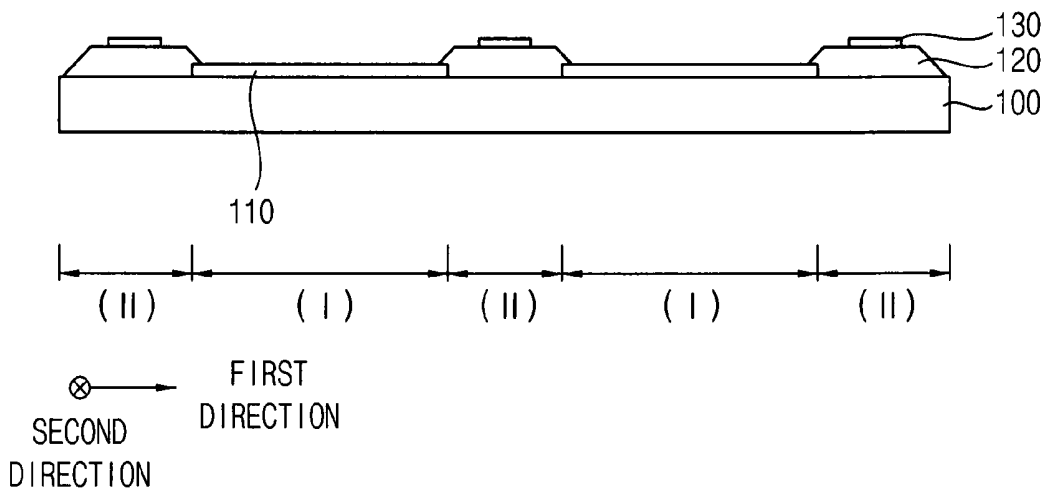

FIG. 7

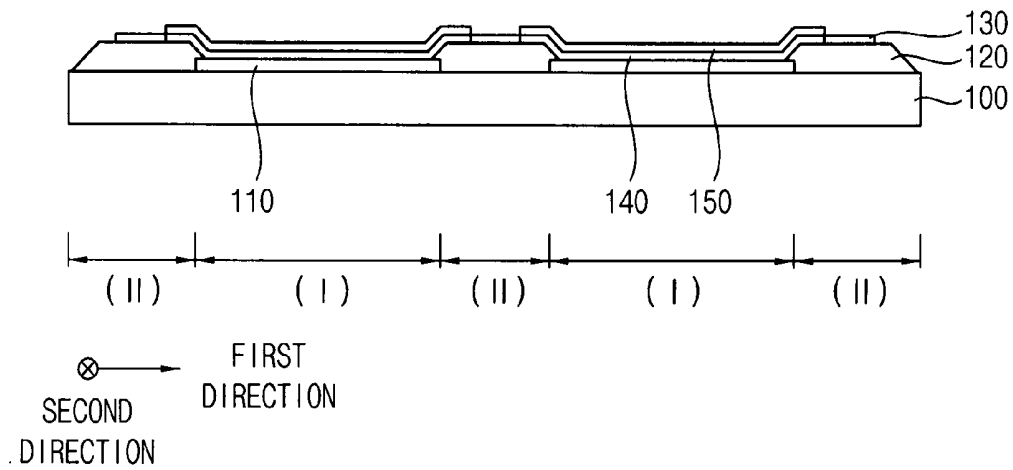

FIG. 8

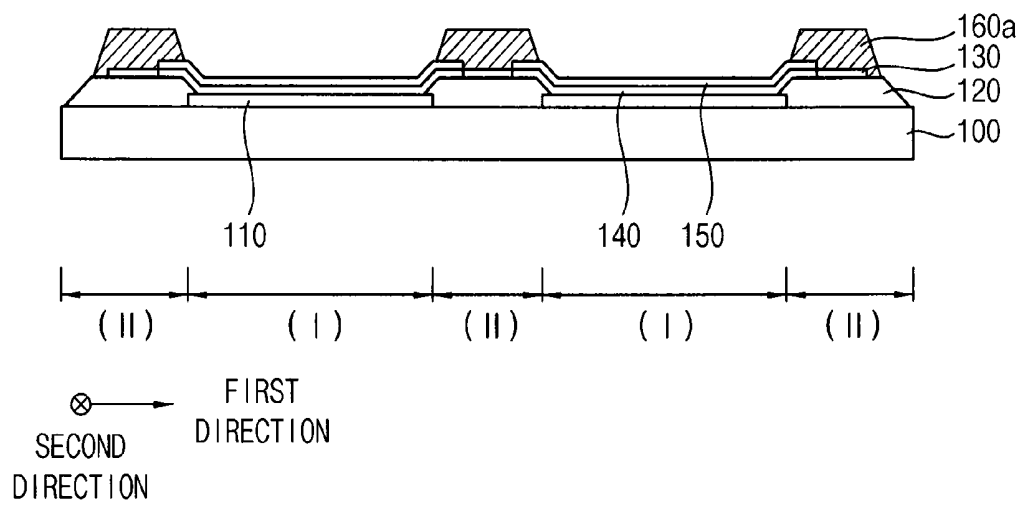

FIG. 9A

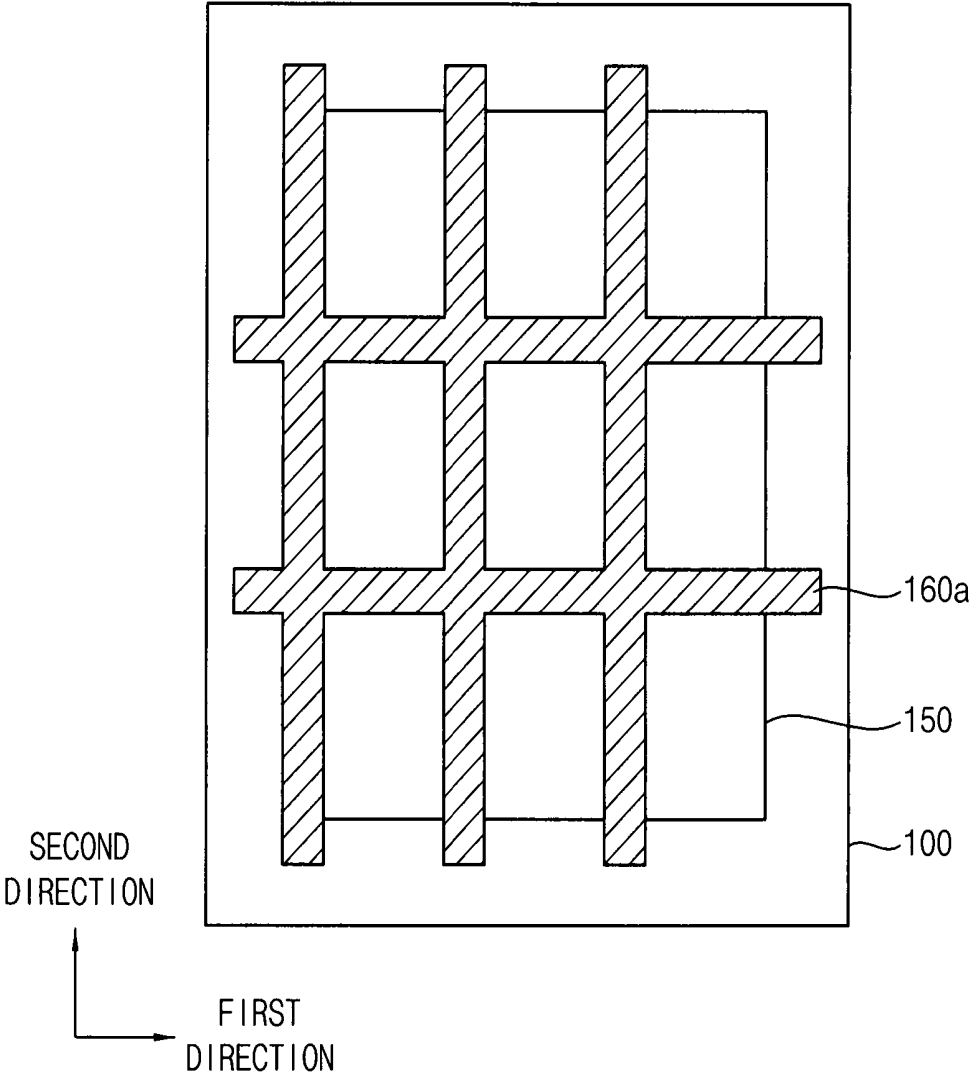

FIG. 9B

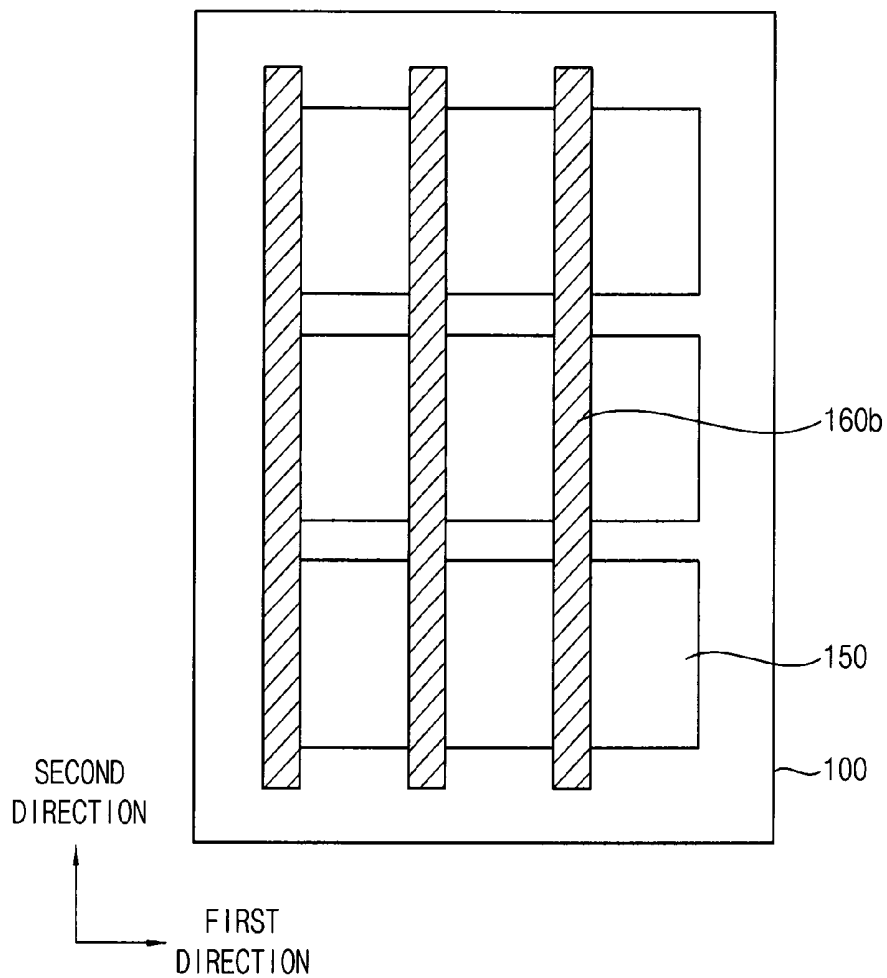

FIG. 10

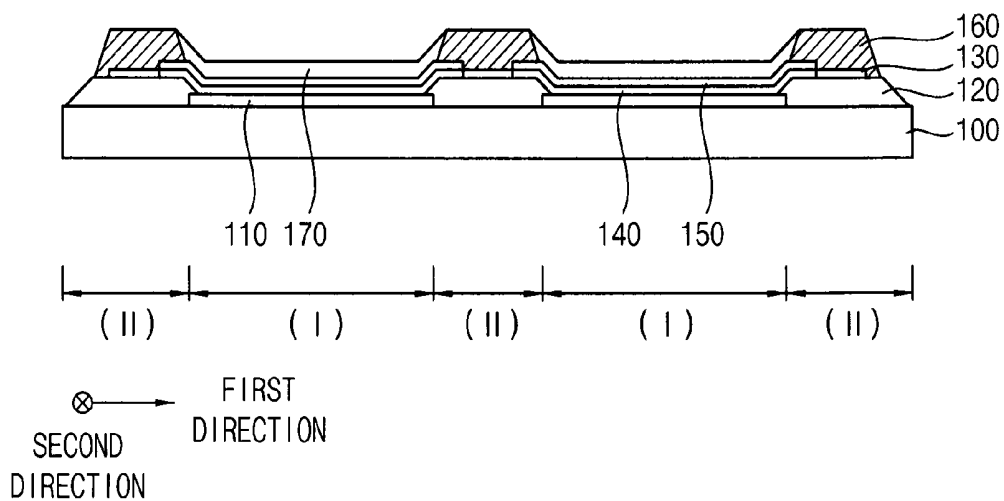

FIG. 11

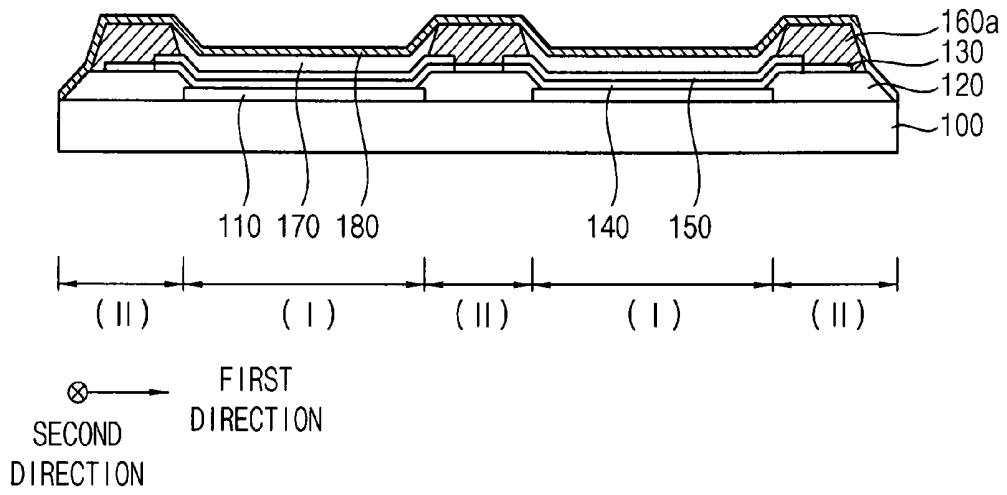

FIG. 12

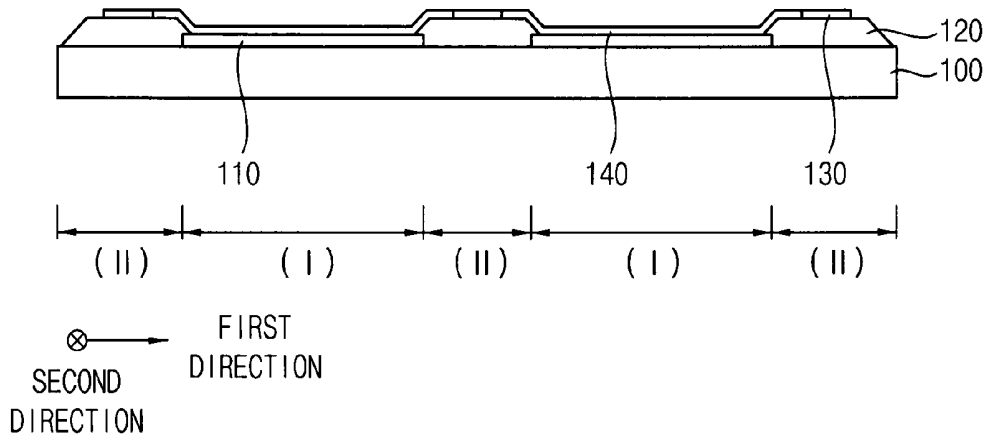

FIG. 13

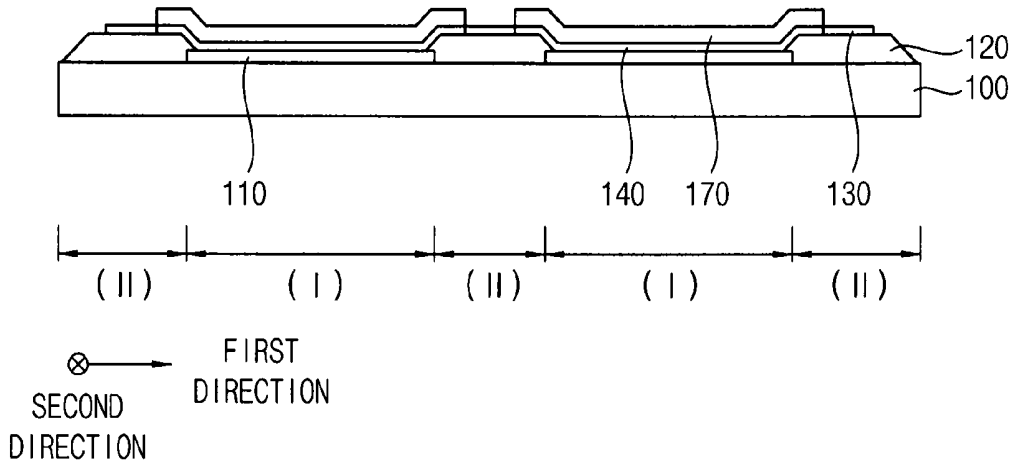
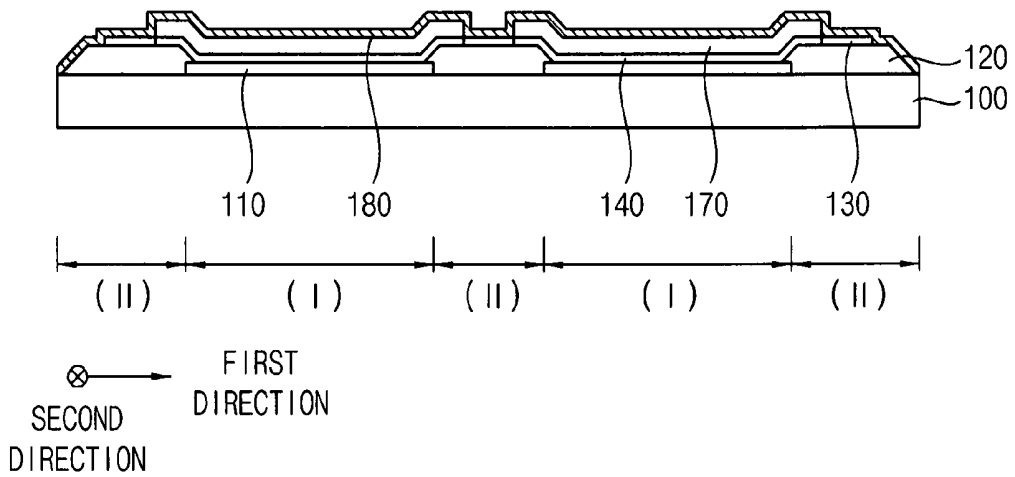

FIG. 14



**ORGANIC LIGHT EMITTING DISPLAY
DEVICES AND METHODS OF
MANUFACTURING ORGANIC LIGHT
EMITTING DISPLAY DEVICES**

**CROSS-REFERENCE TO RELATED
APPLICATION**

[0001] This application claims priority under 35 USC §119 to Korean Patent Application No. 2012-0108682 filed on Sep. 28, 2012 in the Korean Intellectual Property Office (KIPO), the disclosures of which are herein incorporated by reference in their entireties.

BACKGROUND

[0002] 1. Field

[0003] Example embodiments relate to organic light emitting display devices and methods of manufacturing organic light emitting devices. More particularly, example embodiments relate to organic light emitting display devices having improved optical characteristics and methods of manufacturing organic light emitting devices having improved optical characteristics.

[0004] 2. Description of the Related Art

[0005] An organic light emitting display (OLED) device may display desired information such as images, letters and/or characters using a light generated by the combination of holes provided from an anode and electrons provided from a cathode in an organic layer thereof. The OLED device may have several advantages such as wide viewing angle, high response time, thin thickness and low power consumption, so that the OLED device may be widely employed in various electrical and electronic apparatuses. Recently, the OLED device has been rapidly developed as one of the most promising display devices.

[0006] For the conventional organic light emitting display device, a hole injection layer (HIL), a hole transfer layer (HTL), an electron injection layer (EIL) and/or an electron transfer layer (ETL) may be disposed to promote charge carrier (e.g. hole or electron) movement. These layers may have a relatively high conductivity to improve luminance efficiency. However, when these layers are coated on a substrate without a patterning process, a cross talk phenomenon may occur. That is, the charge carrier injected in a selected pixel may leak into adjacent undesired pixel through these layers.

SUMMARY

[0007] Example embodiments provide an organic light emitting display device which may prevent or reduce a cross talk between charge transport layers.

[0008] Example embodiments provide a method of manufacturing an organic light emitting display device which may prevent or reduce a cross talk between charge transport layers.

[0009] According to example embodiments, there is provided an organic light emitting display device including a substrate, a first electrode, a pixel defining layer, a first hydrophobic pattern, at least one charge transport layer, a second hydrophobic pattern, an organic light emitting layer and a second electrode. The substrate has a pixel region and a non pixel region surrounding the pixel region. The first electrode is disposed on the substrate in the pixel region. The pixel defining layer is disposed on the substrate in the non pixel region. The first hydrophobic pattern is disposed on the pixel

defining layer. The at least one charge transport layer is disposed on the first electrode. The second hydrophobic pattern is disposed on the pixel defining layer to cover the first hydrophobic pattern. The organic light emitting layer is disposed on the at least one charge transport layer. The second electrode is disposed on the organic light emitting layer.

[0010] In example embodiments, each of the first hydrophobic pattern and the second hydrophobic pattern may have a surface energy below about 20 dyne/cm²

[0011] In example embodiments, the first hydrophobic pattern may have an electric conductivity smaller than an electric conductivity of the at least one charge transport layer.

[0012] In example embodiments, the pixel defining layer may have a thickness of about 100 nm to about 400 nm.

[0013] In example embodiments, the at least one charge transport layer may include a hole transfer layer and a hole injection layer.

[0014] In example embodiments, the at least one charge transport layer may include an electron transfer layer and an electron injection layer.

[0015] In example embodiments, a portion of the charge transport layer may overlap with the pixel defining layer, and the second hydrophobic pattern may cover the portion of the charge transport layer.

[0016] In example embodiments, the first hydrophobic pattern and the second hydrophobic pattern may not overlap with the first electrode.

[0017] In example embodiments, the first hydrophobic pattern may have a thickness smaller than a thickness of the pixel defining layer, and the second hydrophobic pattern may have a thickness larger than the thickness of the pixel defining layer.

[0018] In example embodiments, the first hydrophobic pattern and the second hydrophobic pattern may extend in a first direction and a second direction substantially perpendicular to the first direction.

[0019] In example embodiments, the first hydrophobic pattern may extend in a first direction and a second direction substantially perpendicular to the first direction, and the second hydrophobic pattern may extend in the second direction.

[0020] According to example embodiments, there is provided a method of manufacturing an organic light emitting display device. In the method, a first electrode is formed on a substrate. A pixel defining layer is formed on the substrate adjacent to the first electrode. A first hydrophobic pattern is formed on the pixel defining layer. At least one charge transport layer is formed on the first electrode. A second hydrophobic pattern is formed on the pixel defining layer to cover the first hydrophobic pattern. An organic light emitting layer is formed on the at least one charge transport layer. A second electrode is formed on the organic light emitting layer and the second hydrophobic pattern.

[0021] In example embodiments, forming the first hydrophobic pattern may be performed by an offset printing process, a gravure offset printing process, a gravure reverse offset printing process, an inkjet printing process, a nozzle printing process, a T-jet process, a stamping process, an electro spray process or a laser induced thermal imaging process, and forming the second hydrophobic pattern may be performed by an offset printing process, a gravure offset printing process, a gravure reverse offset printing process, an inkjet printing process, a nozzle printing process, a T-jet process, a stamping process, an electro spray process or a laser induced thermal imaging process.

[0022] In example embodiments, forming the at least one charge transport layer may be performed by a slit coating process, a bar coating process or a spin coating process. The at least one charge transport layer may cover the first electrode completely, and the at least one charge transport layer may cover the pixel defining layer partially.

[0023] In example embodiments, the at least one charge transport layer may include a hole transfer layer and a hole injection layer.

[0024] In example embodiments, the at least one charge transport layer may include an electron transfer layer and an electron injection layer.

[0025] In example embodiments, the substrate may have a plurality of pixel regions and a non pixel region surrounding the plurality of pixel regions, and the plurality of pixel regions is arranged in a first direction and a second direction substantially perpendicular to the first direction. The first electrode may be formed in the pixel regions, and the pixel defining layer, the first hydrophobic pattern and the second hydrophobic pattern may be formed in the non pixel region.

[0026] In example embodiments, a portion of the charge transport layer may overlap with the pixel defining layer, and the second hydrophobic pattern may cover the portion of the charge transport layer.

[0027] In example embodiments, the first hydrophobic pattern and the second hydrophobic pattern may partially or completely cover the pixel defining layer.

[0028] According to some example embodiments, there is provided a method of manufacturing an organic light emitting display device. In the method, a first electrode is formed on a substrate. A pixel defining layer is formed on the substrate adjacent to the first electrode. A first hydrophobic pattern is formed on the pixel defining layer. At least one charge transport layer is formed on the first electrode. An organic light emitting layer is formed on the at least one charge transport layer. A second electrode is formed on the organic light emitting layer and the second hydrophobic pattern. The first hydrophobic pattern may have an electric conductivity lower than an electric conductivity of the at least one charge transport layer.

[0029] According to example embodiments, a first hydrophobic pattern having a relatively small electric conductivity may be disposed on a pixel defining layer, so that each of hole injection layers and each of hole transfer layers may be separated from each other. Therefore, a cross talk phenomenon may be prohibited or reduced. That is, a hole injected into the hole injection layer and the hole transfer layer in a selected pixel region (I) may not migrate to the hole injection layer and the hole transfer layer in an unselected pixel region (I). Further, the second hydrophobic pattern may have a relatively large thickness, so that a material of the each organic light emitting layer may not be mixed from each other.

BRIEF DESCRIPTION OF THE DRAWINGS

[0030] Example embodiments will be more clearly understood from the following detailed description taken in conjunction with the accompanying drawings. FIGS. 1 to 14 represent non-limiting, example embodiments as described herein.

[0031] FIG. 1 is a plan view illustrating an organic light emitting display device in accordance with example embodiments;

[0032] FIG. 2 is a cross-sectional view illustrating organic light emitting display devices in accordance with example embodiments;

[0033] FIG. 3 is a cross-sectional view illustrating organic light emitting display devices in accordance with some example embodiments;

[0034] FIGS. 4 to 11 are cross-sectional views illustrating a method of manufacturing an organic light emitting display device in accordance with example embodiments; and

[0035] FIGS. 12 to 14 are cross-sectional views illustrating a method of manufacturing an organic light emitting display device in accordance with some example embodiments.

DESCRIPTION OF EMBODIMENTS

[0036] Various example embodiments will be described more fully hereinafter with reference to the accompanying drawings, in which some example embodiments are shown. The invention may, however, be embodied in many different forms and should not be construed as limited to the example embodiments set forth herein. Rather, these example embodiments are provided so that this description will be thorough and complete, and will fully convey the scope of the invention to those skilled in the art. In the drawings, the sizes and relative sizes of layers and regions may be exaggerated for clarity.

[0037] It will be understood that when an element or layer is referred to as being “on,” “connected to” or “coupled to” another element or layer, it can be directly on, connected or coupled to the other element or layer or intervening elements or layers may be present. In contrast, when an element is referred to as being “directly on,” “directly connected to” or “directly coupled to” another element or layer, there are no intervening elements or layers present. Like numerals refer to like elements throughout. As used herein, the term “and/or” includes any and all combinations of one or more of the associated listed items.

[0038] It will be understood that, although the terms first, second, third etc. may be used herein to describe various elements, components, regions, layers and/or sections, these elements, components, regions, layers and/or sections should not be limited by these terms. These terms are only used to distinguish one element, component, region, layer or section from another region, layer or section. Thus, a first element, component, region, layer or section discussed below could be termed a second element, component, region, layer or section without departing from the teachings of the invention.

[0039] Spatially relative terms, such as “beneath,” “below,” “lower,” “above,” “upper” and the like, may be used herein for ease of description to describe one element or feature’s relationship to another element(s) or feature(s) as illustrated in the figures. It will be understood that the spatially relative terms are intended to encompass different orientations of the device in use or operation in addition to the orientation depicted in the figures. For example, if the device in the figures is turned over, elements described as “below” or “beneath” other elements or features would then be oriented “above” the other elements or features. Thus, the exemplary term “below” can encompass both an orientation of above and below. The device may be otherwise oriented (rotated 90 degrees or at other orientations) and the spatially relative descriptors used herein interpreted accordingly.

[0040] The terminology used herein is for the purpose of describing particular example embodiments only and is not intended to be limiting of the invention. As used herein, the

singular forms “a,” “an” and “the” are intended to include a plurality of forms as well, unless the context clearly indicates otherwise. It will be further understood that the terms “comprises” and/or “comprising,” when used in this specification, specify the presence of stated features, integers, steps, operations, elements, and/or components, but do not preclude the presence or addition of one or more other features, integers, steps, operations, elements, components, and/or groups thereof.

[0041] Example embodiments are described herein with reference to cross-sectional illustrations that are schematic illustrations of idealized example embodiments (and intermediate structures). As such, variations from the shapes of the illustrations as a result, for example, of manufacturing techniques and/or tolerances, are to be expected. Thus, example embodiments should not be construed as limited to the particular shapes of regions illustrated herein but are to include deviations in shapes that result, for example, from manufacturing. For example, an implanted region illustrated as a rectangle will, typically, have rounded or curved features and/or a gradient of implant concentration at its edges rather than a binary change from implanted to non-implanted region. Likewise, a buried region formed by implantation may result in some implantation in the region between the buried region and the face through which the implantation takes place. Thus, the regions illustrated in the figures are schematic in nature and their shapes are not intended to illustrate the actual shape of a region of a device and are not intended to limit the scope of the invention.

[0042] Unless otherwise defined, all terms (including technical and scientific terms) used herein have the same meaning as commonly understood by one of ordinary skill in the art to which this invention belongs. It will be further understood that terms, such as those defined in commonly used dictionaries, should be interpreted as having a meaning that is consistent with their meaning in the context of the relevant art and will not be interpreted in an idealized or overly formal sense unless expressly so defined herein.

[0043] FIG. 1 is a plan view illustrating an organic light emitting display device in accordance with example embodiments, and FIG. 2 is a cross-sectional view cut along line I-II of FIG. 1.

[0044] Referring to FIGS. 1 and 2, the organic light emitting display (OLED) device may include a substrate **100**, a first electrode **110**, a pixel defining layer **120**, a first hydrophobic pattern **130**, at least one charge transport layer, a second hydrophobic pattern **160a**, an organic light emitting layer **170** and a second electrode **180**. In example embodiments, the at least one charge transport layer may include a hole injection layer (HIL) **140** and/or a hole transfer layer (HTL) **150**.

[0045] The substrate **100** may include a transparent substrate such as a glass substrate, a quartz substrate, a transparent plastic substrate, etc. For example, the transparent plastic substrate may include polyimide, acryl-based resin, polyethylene terephthalate (PET), polycarbonate, polyacrylate, polyether, etc.

[0046] The substrate **100** may include a plurality of pixel regions (I) and a non pixel region (II). The plurality of pixel regions (I) may be arranged in a first direction and a second direction substantially perpendicular to the first direction, and the non pixel region (II) may surround the plurality of pixel regions (I). The plurality of pixel regions (I) may correspond to regions for generating a light from the organic light emit-

ting layer **170**, and the non pixel region (II) may separate the plurality of pixel regions (I) from each other.

[0047] The first electrode **110** may be disposed on the substrate **100** in the pixel region (I). The first electrode **110** may be a reflective electrode or a transmissive electrode depending on an emission type of the OLED device. In example embodiments, when the first electrode **110** is the transmissive electrode, the first electrode **110** may include indium tin oxide (ITO), indium zinc oxide (IZO), zinc tin oxide (ZTO), gallium tin oxide (GTO), zinc oxide (ZnOx), indium oxide (InOx), tin oxide (SnOx), gallium oxide (GaOx), mixtures thereof. In some example embodiments, when the first electrode **110** is the reflective electrode, the first electrode **110** may include aluminum (Al), tungsten (W), copper (Cu), nickel (Ni), chromium (Cr), molybdenum (Mo), titanium (Ti), platinum (Pt), silver (Ag), tantalum (Ta), ruthenium (Ru), alloys thereof.

[0048] When the OLED device has an active matrix type, a switching structure (not illustrated) may be disposed between the substrate **100** and the first electrode **110**. The switching structure may include a switching device (not illustrated) and at least one of insulation layers (not illustrated). In example embodiments, the switching device may include a thin film transistor having a semiconductor layer containing silicon. In some example embodiments, the switching device may include an oxide semiconductor device having an active layer containing semiconductor oxide. In this case, the first electrode **110** may be electrically connected to the switching device.

[0049] The pixel defining layer **120** may be disposed on the substrate in the non pixel region (II). In example embodiments, the pixel defining layer **120** may be disposed adjacent to the first electrode **110**, and a portion of the pixel defining layer **120** may overlap with the first electrode **110**. Alternatively, the pixel defining layer **120** may not overlap with the first electrode **110**. In example embodiments, the pixel defining layer **120** on the substrate **100** may extend in the first direction and the second direction as illustrated in FIG. 1. For example, the pixel defining layer **120** may have a first thickness (T1) of about 100 nm to about 400 nm.

[0050] A sidewall of the pixel defining layer **120** may have a predetermined angle with respect to an upper surface of the substrate **100**. For example, the sidewall of the pixel defining layer **120** may have the angle below about 45 degrees with respect to the upper surface of the substrate **100**. That is, the pixel defining layer **120** may have a relatively gradual slope.

[0051] The first hydrophobic pattern **130** may be disposed on the pixel defining layer **120** in the non pixel region (II). The first hydrophobic pattern **130** may extend in the first direction and the second direction. In this case, the first hydrophobic pattern **130** may not overlap with the first electrode **110**. In example embodiments, the first hydrophobic pattern **130** may partially cover the pixel defining layer **120**. Alternatively, the first hydrophobic pattern **130** may cover the pixel defining layer **120** sufficiently or completely.

[0052] In example embodiments, the first hydrophobic pattern **130** may include a material which has a relatively small electric conductivity, and a hydrophobic characteristic, that is having a relatively small surface energy. For example, the first hydrophobic pattern **130** may have a second thickness (T2) of about 30 nm to about 100 nm. That is, the second thickness (T2) of the first hydrophobic pattern **130** may be smaller than the first thickness (T1) of the pixel defining layer **120**.

[0053] The hole injection layer (HIL) **140** may be disposed on the first electrode **110** and the pixel defining layer **120**. The hole injection layer **140** may promote a hole injection from the first electrode **110** into the organic light emitting layer **170**. For example, the hole injection layer **140** may include CuPc(copper phthalocyanine), PEDOT(poly(3,4)-ethylene-dioxythiophene), PANI(polyaniline), NPD(N,N-dinaphthyl-N,N'-diphenyl benzidine), etc., however, a material in the hole injection layer **140** may not be limited thereto. In example embodiment, a plurality of hole injection layers **140** may be arranged in the first direction and the second direction depending on the arrangement of the pixel regions (I).

[0054] The hole transfer layer (HTL) **150** may be located on the hole injection layer **140**. The hole transfer layer **150** may improve a hole movement from the hole injection layer **140**. For example, the hole transfer layer **150** may include NPD(N,N-dinaphthyl-N,N'-diphenylbenzidine), TPD(N,N'-bis-(3-methylphenyl)-N,N'-bis-(phenyl)-benzidine), s-TAD, MTDATA (4,4',4''-Tris(N-3-methylphenyl-N-phenyl-amino)-triphenylamine), etc., however, a material in the hole transfer layer **150** may not be limited thereto. In example embodiment, a plurality of hole transfer layers **150** may be arranged in the first direction and the second direction depending on the arrangement of the pixel regions (I).

[0055] In example embodiments, the hole injection layer **140** and the hole transfer layer **150** may be disposed not to overlap with the first hydrophobic pattern **130** having a relatively small surface energy. Therefore, each of the hole injection layers **140** and each of the hole transfer layers **150** may be electrically separated from each other.

[0056] The second hydrophobic pattern **160b** may be disposed on the pixel defining layer **120**, the first hydrophobic pattern **130** and/or the hole transfer layer **150** in the non pixel region (II). The second hydrophobic pattern **160a** may not overlap with the first electrode **110**. In example embodiments, the second hydrophobic pattern **160a** may partially cover the pixel defining layer **120**. In some example embodiments, the second hydrophobic pattern **160** may cover the pixel defining layer **120** sufficiently or completely.

[0057] In example embodiments, the second hydrophobic pattern **160a** may extend in the first direction and the second direction to form a lattice structure as illustrated in FIG. 9A. In some example embodiments, the second hydrophobic pattern **160b** may extend in the second direction as illustrated in FIG. 9B.

[0058] The second hydrophobic pattern **160a** may include a hydrophobic material having a surface energy below about 20 dyne/cm². Also, the second hydrophobic pattern **160a** may have a third thickness (T3) of about 500 nm to about 3 μm. That is, the third thickness (T3) of the second hydrophobic pattern **160a** may be larger than the first thickness (T1) of the pixel defining layer **120**.

[0059] The organic light emitting layer **170** may be disposed on an upper surface of the hole transfer layer **150**, an upper surface of the pixel defining layer **120**, a sidewall of the second hydrophobic pattern **160a**. A portion of the organic light emitting layer **170** on the side wall of the second hydrophobic pattern **160a** may have a substantially uneven thickness. Whereas, the first hydrophobic pattern **130** and the second hydrophobic pattern **160a** may be disposed not to overlap with the first electrode **110** in the pixel region (I), so that a portion of the organic light emitting layer **170** on the hole transfer layer **150** in the pixel region (I) may have a substantially even thickness. That is, the organic light emit-

ting layer **170** may have a substantially even thickness in the pixel region (I), so that the organic light emitting layer **170** may generate a light having a substantially even intensity in the pixel region (I).

[0060] The organic light emitting layer **170** may include an organic material or a mixture of an organic material and an inorganic material generating at least one of a red color of light, a green color of light, and a blue color of light. In some example embodiments, the organic light emitting layer **170** include a stacked structure including light emitting layers for the red color of light, the green color of light, and the blue color of light to generate a white color of light.

[0061] The second electrode **180** may cover the organic light emitting layer **170** and the second hydrophobic pattern **160a** in the pixel region (I) and the non pixel region (II). The second electrode **180** may be a reflective electrode or a transmissive electrode depending on the type of the first electrode **110**. When the first electrode **110** is the transmissive electrode, the second electrode **180** may be the reflective electrode. In this case, the second electrode **180** may include Al, W, Cu, Ni, Cr, Mo, Ti, Pt, Ag, Ta, Ru, alloys thereof. Alternatively, when the first electrode **110** is the reflective electrode, the second electrode **180** may be the transmissive electrode, and may include ITO, IZO, ZTO, GTO, ZnOx, InOx, SnOx, GaOx or mixtures thereof.

[0062] In example embodiments, the first electrode **110** may serve as an anode, and the hole injection layer **140** and the hole transfer layer **150** may be disposed between the first electrode **110** and the organic light emitting layer **170** as illustrated in FIG. 2. However, the inventive concept may not be limited to the above-described construction. In some example embodiments, the first electrode **110** may serve as a cathode. In this case, an electron transfer layer and an electron injection layer may be disposed between the first electrode **110** and the organic light emitting layer **170**.

[0063] According to example embodiments, the first hydrophobic pattern **130** having a relatively small electric conductivity may be disposed on the pixel defining layer **120**, so that each of the hole injection layers **140** and each of the hole transfer layers **150** may be separated from each other. Therefore, a cross talk phenomenon may be prohibited or reduced. That is, a hole injected into the hole injection layer **140** and the hole transfer layer **150** in a selected pixel region (I) may not migrate to the hole injection layer **140** and the hole transfer layer **150** in an unselected pixel region (I). Further, the second hydrophobic pattern **160a** may have a relatively large thickness, so that a material of the each organic light emitting layer **170** may not be mixed from each other.

[0064] FIG. 3 is a cross-sectional view illustrating organic light emitting display devices in accordance with some example embodiments.

[0065] Referring to FIG. 3, the OLED device may include a substrate **100**, a first electrode **110**, a pixel defining layer **120**, a first hydrophobic pattern **130**, a hole injection layer **140**, an organic light emitting layer **170** and a second electrode **180**. The OLED device illustrated in FIG. 3 may have a construction substantially the same as or substantially similar to that of the OLED device described with reference to FIGS. 1 and 2 except for a hole transfer layer **150** and a second hydrophobic pattern **160a**.

[0066] The first electrode **110** may be disposed on the substrate **100** in the pixel region (I), and the pixel defining layer **120** may be disposed on the substrate **100** in the non pixel region (II).

[0067] The first hydrophobic pattern 130 may be disposed to cover the pixel defining layer 120 partially or completely. The first hydrophobic pattern 130 may include a material having a relatively small electric conductivity and a hydrophobic characteristic. Also, the first hydrophobic pattern 130 may have a thickness of about 30 nm to about 100 nm.

[0068] The hole injection layer 140 may be disposed on the first electrode 110 and the pixel defining layer 120, and the organic light emitting layer 170 may be disposed on the hole injection layer 140. A hole transfer layer (not illustrated) may be further disposed between the hole injection layer and the organic light emitting layer 170. The hole injection layer 140 and the organic light emitting layer 170 may include material substantially the same as or substantially similar to those of the hole injection layer 140 and the organic light emitting layer 170 described with reference to FIG. 2.

[0069] The second electrode 180 may cover the organic light emitting layer 170 and the first hydrophobic pattern 130 in the pixel region (I) and the non pixel region (II).

[0070] According to example embodiments, the first hydrophobic pattern 130 having a relatively small electric conductivity may be disposed on the pixel defining layer 120, so that each of the hole injection layers 140 may be separated from each other. Therefore, a cross talk phenomenon may be prohibited or reduced. That is, a hole injected into the hole injection layer 140 in a selected pixel region (I) may not migrate to the hole injection layer 140 and in an unselected pixel region (I).

[0071] FIGS. 4 to 11 are cross-sectional views illustrating a method of manufacturing an organic light emitting display device in accordance with example embodiments. FIGS. 9a and 9b are cross-sectional views illustrating a method of manufacturing an organic light emitting display device in accordance with different example embodiments.

[0072] Referring to FIG. 4, a first electrode 110 may be formed on a substrate 100

[0073] In example embodiments, the substrate 100 may include a transparent substrate such as a glass substrate, a quartz substrate, a transparent plastic substrate, etc. Further, the substrate 100 may include a flexible substrate. The substrate 100 may include a plurality of pixel regions (I) and a non pixel region (II). The plurality of pixel regions (I) may be arranged in a first direction and a second direction substantially perpendicular to the first direction, and the non pixel region (II) may surround the plurality of pixel regions (I).

[0074] The first electrode 110 may be formed on the substrate 100 in the pixel region (I). After forming a conductive layer on the substrate, the conductive layer may be patterned to form the first electrode 110. Therefore, a plurality of first electrodes 110 may be formed to correspond to the plurality of pixel regions (I).

[0075] The first electrode 110 may be a reflective electrode or a transmissive electrode depending on an emission type of the OLED device. When the OLED device has a bottom emission type, the conductive layer may be formed using ITO, IZO, ZTO, GTO, ZnOx, InOx, SnOx, GaOx, mixtures thereof. When the OLED device has a top emission type, the conductive layer may be formed using Al, W, Cu, Ni, Cr, Mo, Ti, Pt, Ag, Ta, Ru, alloys thereof.

[0076] When the OLED device has an active matrix type, the switching structure (not illustrated) may be formed between the substrate 100 and the first electrode 110. The switching structure may be electrically connected to the first electrode 110.

[0077] Referring to FIG. 5, a pixel defining layer 120 may be formed on the substrate 100. The pixel defining layer 120 may be formed to correspond to the non pixel region (II) of the substrate 100. In this case, the pixel defining layer 120 may be formed adjacent to the first electrode 110, and a portion of the pixel defining layer 120 may overlap with the first electrode 110. In example embodiments, the pixel defining layer 120 may expand in the first direction and the second direction. For example, the pixel defining layer 120 may have a relatively small thickness of about 100 nm to about 400 nm.

[0078] A sidewall of the pixel defining layer 120 may have a predetermined angle with respect to an upper surface of the substrate 100. For example, the sidewall of the pixel defining layer 120 may have an angle below about 45 degrees with respect to the upper surface of the substrate 100. That is, the pixel defining layer 120 may have a relatively gradual slope.

[0079] Referring to FIG. 6, a first hydrophobic pattern 130 may be formed on the pixel defining layer 120. The first hydrophobic pattern 130 may be formed by an offset printing process, a gravure offset printing process, a gravure reverse offset printing process, an inkjet printing process, a nozzle printing process, a T-jet process, a stamping process, an electro spray process or a laser induced thermal imaging process.

[0080] The first hydrophobic pattern 130 may be formed using a material having a relatively small electric conductivity and having a hydrophobic characteristic. For example, the first hydrophobic pattern 130 may have an electric conductivity smaller than that of the charge transport layers which may be formed on the first electrode 110. Also, the first hydrophobic pattern 130 may have a surface energy below about 20 dyne/cm², and may have a thickness of about 30 nm to about 100 nm.

[0081] In example embodiments, the first hydrophobic pattern 130 may partially cover the pixel defining layer 120, or completely cover the pixel defining layer 120. In this case, the first hydrophobic pattern 130 may not overlap with the first electrode 110.

[0082] Referring to FIG. 7, at least one charge transport layer may be formed on the first electrode 110. In example embodiments, the charge transport layer may include a hole injection layer 140 and/or a hole transfer layer 150. The hole injection layer 140 may be formed on the first electrode 110 and the pixel defining layer 120 by a slit coating process, a bar coating process or a spin coating process. On the other hand, the hole transfer layer 150 may be formed on the hole injection layer 140 by a slit coating process, a bar coating process or a spin coating process.

[0083] In example embodiments, during the coating process for forming the hole injection layer 140 and the hole transfer layer 150, a coating solution may be sufficiently coated on the substrate 100 having the first electrode 110 and the pixel defining layer 120. The pixel defining layer 120 may have a relatively small thickness below about 400 nm, and the sidewall of the pixel defining layer 120 may have an angle below about 45 degrees with respect to the upper surface of the substrate 100, so that the coating solution may be coated on the first electrode 110 and the pixel defining layer 120 conformally. However, the coating solution may not be coated on the first hydrophobic pattern 130 having a relatively small surface energy. Therefore, the hole injection layer 140 and the hole transfer layer 150 may be formed to correspond to the plurality of pixel regions (I) without a patterning process. Further, the first hydrophobic pattern 130 may have an electrical conductivity smaller than those of the hole injection

layer **140** and the hole transfer layer **150**, so that a cross talk phenomenon may be prohibited or reduced. That is, a hole injected into the hole injection layer **140** and the hole transfer layer **150** in a selected pixel region (I) may not migrate to the hole injection layer **140** and the hole transfer layer **150** in an unselected pixel region (I).

[0084] Referring to FIG. 8, a second hydrophobic pattern **160a** may be formed on the pixel defining layer **120** to cover the first hydrophobic pattern **130**. The second hydrophobic pattern **160a** may be formed by a process substantially the same or substantially similar to the process for forming the first hydrophobic pattern **130**.

[0085] In example embodiments, the second hydrophobic pattern **160a** may be formed using a hydrophobic material having a surface energy below about 20 dyne/cm². For example, the second hydrophobic pattern **160a** may have a thickness of about 500 nm to about 3 μm.

[0086] In example embodiments, the second hydrophobic pattern **160a** may partially or completely cover the pixel defining layer **120**. The second hydrophobic pattern **160a** may not overlap with the first electrode **110**.

[0087] In example embodiments, the second hydrophobic pattern **160a** may extend in the first direction and the second direction to form a lattice structure as illustrated in FIG. 9a. In other example embodiments, the second hydrophobic pattern **160b** may extend in the second direction as illustrated in FIG. 9b.

[0088] Referring to FIG. 10, an organic light emitting layer **170** may be formed on the hole transfer layer **150**.

[0089] The organic light emitting layer **170** may be formed on an upper surface of the hole transfer layer **150** and a side wall of the second hydrophobic pattern **160a** by a liquid phase patterning process. For example, the liquid phase patterning process may include an inkjet printing process, a nozzle printing process, a T-jet process, a stamping process or an electro spray process. A portion of the organic light emitting layer **170** on the side wall of the second hydrophobic pattern **160a** may have a substantially uneven thickness. Whereas, the first hydrophobic pattern **130** and the second hydrophobic pattern **160a** may be disposed not to overlap with the first electrode **110** in the pixel region (I), so that a portion of the organic light emitting layer **170** on the hole transfer layer **150** in the pixel region (I) may have a substantially even thickness. That is, the organic light emitting layer **170** may have a substantially even thickness in the pixel region (I), so that the organic light emitting layer **170** may generate a light having a substantially even intensity in the pixel region (I).

[0090] The organic light emitting layer **170** may include an organic material or a mixture of an organic material and an inorganic material generating at least one of a red color of light, a green color of light, and a blue color of light. In some example embodiments, the organic light emitting layer **170** include a stacked structure including light emitting layers for the red color of light, the green color of light, and the blue color of light to generate a white color of light.

[0091] In example embodiments, each of the pixel regions (I) may be separated by the second hydrophobic pattern **160a** having a relatively large thickness, so that one organic material for one pixel region (I) may not be mixed with other organic material for other pixel region (I) during the liquid phase patterning process.

[0092] In other example embodiments, when the OLED device has a pixel arrangement of traditional RGB type, that is pixel regions of the same color are arranged in the second

direction, the second hydrophobic pattern **160b** extending in the second direction may prevent or reduce the mixture of the organic material.

[0093] Referring to FIG. 11, the second electrode **180** may be formed on the organic light emitting layer **170** and the second hydrophobic pattern **160a** in the pixel region (I) and the non pixel region (II).

[0094] The second electrode **180** may be a reflective electrode or a transmissive electrode depending on the type of the first electrode **110**. When the first electrode **110** is the transmissive electrode, the second electrode **180** may be the reflective electrode. In this case, the second electrode **180** may be formed using Al, W, Cu, Ni, Cr, Mo, Ti, Pt, Ag, Ta, Ru or alloys thereof. Alternatively, when the first electrode **110** is the reflective electrode, the second electrode **180** may be the transmissive electrode, and may be formed using ITO, IZO, ZTO, GTO, ZnOx, InOx, SnOx, GaOx, mixtures thereof

[0095] In example embodiments, the first electrode **110** may serve as an anode, and the hole injection layer **140** and the hole transfer layer **150** may be disposed between the first electrode **110** and the organic light emitting layer **170**. However, the inventive concept may not be limited to the above-described construction. In some example embodiments, the first electrode **110** may serve as a cathode. In this case, an electron transfer layer and an electron injection layer may be disposed between the first electrode **110** and the organic light emitting layer **170**.

[0096] According to example embodiments, the first hydrophobic pattern **130** having a relatively small electric conductivity may be disposed on the pixel defining layer **120**, so that each of the hole injection layers **140** and each of the hole transfer layers **150** may be separated from each other. Therefore, a cross talk phenomenon may be prohibited. That is, a hole injected into the hole injection layer **140** and the hole transfer layer **150** in the selected pixel region (I) may not migrate to the hole injection layer **140** and the hole transfer layer **150** in the unselected pixel region (I). Further, the second hydrophobic pattern **160a** may have a relatively large thickness, so that a material of the each organic light emitting layer **170** may not be mixed from each other.

[0097] FIGS. 12 to 14 are cross-sectional views illustrating a method of manufacturing an organic light emitting display device in accordance with some example embodiments.

[0098] Referring to FIG. 12, a first electrode **110**, a pixel defining layer **120**, a first hydrophobic pattern **130** and a hole injection layer **140** may be formed on a substrate **100**. Processes for forming the first electrode **110**, the pixel defining layer **120**, the first hydrophobic pattern **130** and the hole injection layer **140** may be substantially the same as or substantially similar to those for forming the first electrode **110**, the pixel defining layer **120**, the first hydrophobic pattern **130** and the hole injection layer **140** described with reference to FIGS. 4 to 6.

[0099] The hole injection layer **140** may be formed on the first electrode **110** and the pixel defining layer **120** by a slit coating process, a bar coating process or a spin coating process. In this case, the hole injection layer **140** may not be formed on the first hydrophobic pattern **130** having a relatively small surface energy. Further, the first hydrophobic pattern **130** may have an electrical conductivity smaller than that of the hole injection layer **140**, so that a cross talk phenomenon may be prohibited. That is, a hole injected into the

hole injection layer **140** in the selected pixel region (I) may not migrate to the hole injection layer **140** in the unselected pixel region (I).

[0100] Referring to FIG. 13, an organic light emitting layer **170** may be formed on the hole injection layer **140**.

[0101] The organic light emitting layer **170** may be formed on an upper surface of the hole injection layer **140** by an inkjet printing process, a nozzle printing process, a T-jet process, a stamping process or an electro spray process.

[0102] The organic light emitting layer **170** may be disposed not to overlap with the first hydrophobic pattern **130**, so that a portion of the organic light emitting layer **170** on the hole transfer layer **150** in the pixel region (I) may have a substantially even thickness. That is, the organic light emitting layer **170** may have a substantially even thickness in the pixel region (I), so that the organic light emitting layer **170** may generate a light having a substantially even intensity in the pixel region (I).

[0103] In example embodiments, each of the pixel regions (I) may be separated by the first hydrophobic pattern **130**, so that one organic light emitting layer **170** for one pixel region (I) may not be mixed with other organic light emitting layer **170** for other pixel region (I).

[0104] Referring to FIG. 14, the second electrode **180** may be formed on the organic light emitting layer **170** and the first hydrophobic pattern **130** in the pixel region (I) and the non pixel region (II). The second electrode **180** may completely cover the pixel region (I) and the non pixel region (II). The second electrode **180** may be formed by a process substantially the same or substantially similar to the process described with reference to FIG. 11.

[0105] The foregoing is illustrative of example embodiments and is not to be construed as limiting thereof. Although a few example embodiments have been described, those skilled in the art will readily appreciate that many modifications are possible in the example embodiments without materially departing from the novel teachings and advantages of the invention. Accordingly, all such modifications are intended to be included within the scope of the invention as defined in the claims. In the claims, means-plus-function clauses are intended to cover the structures described herein as performing the recited function and not only structural equivalents but also equivalent structures. Therefore, it is to be understood that the foregoing is illustrative of various example embodiments and is not to be construed as limited to the specific example embodiments disclosed, and that modifications to the disclosed example embodiments, as well as other example embodiments, are intended to be included within the scope of the appended claims.

1. An organic light emitting display device, comprising:
 - a substrate having a pixel region and a non pixel region surrounding the pixel region;
 - a first electrode disposed on the substrate in the pixel region;

a pixel defining layer disposed on the substrate in the non pixel region;

a first hydrophobic pattern disposed on the pixel defining layer;

at least one charge transport layer disposed on the first electrode;

a second hydrophobic pattern disposed on the pixel defining layer to cover the first hydrophobic pattern;

an organic light emitting layer disposed on the at least one charge transport layer; and

a second electrode disposed on the organic light emitting layer.

2. The organic light emitting display device of claim 1, wherein each of the first hydrophobic pattern and the second hydrophobic pattern has a surface energy below about 20 dyne/cm².

3. The organic light emitting display device of claim 1, wherein the first hydrophobic pattern has an electric conductivity smaller than an electric conductivity of the at least one charge transport layer.

4. The organic light emitting display device of claim 1, wherein the pixel defining layer has a thickness of about 100 nm to about 400 nm.

5. The organic light emitting display device of claim 1, wherein the at least one charge transport layer includes a hole transfer layer and a hole injection layer.

6. The organic light emitting display device of claim 1, wherein the at least one charge transport layer includes an electron transfer layer and an electron injection layer.

7. The organic light emitting display device of claim 1, wherein a portion of the charge transport layer overlaps the pixel defining layer, and wherein the second hydrophobic pattern covers the portion of the charge transport layer.

8. The organic light emitting display device of claim 1, wherein the first hydrophobic pattern and the second hydrophobic pattern do not overlap with the first electrode.

9. The organic light emitting display device of claim 1, wherein the first hydrophobic pattern has a thickness smaller than a thickness of the pixel defining layer, and the second hydrophobic pattern has a thickness larger than the thickness of the pixel defining layer.

10. The organic light emitting display device of claim 9, wherein the first hydrophobic pattern and the second hydrophobic pattern extend in a first direction and a second direction substantially perpendicular to the first direction.

11. The organic light emitting display device of claim 9, wherein the first hydrophobic pattern extends in a first direction and a second direction substantially perpendicular to the first direction, and the second hydrophobic pattern extends in the second direction.

12-20. (canceled)

* * * * *

专利名称(译)	有机发光显示装置和制造有机发光显示装置的方法		
公开(公告)号	US20150303243A1	公开(公告)日	2015-10-22
申请号	US14/754654	申请日	2015-06-29
[标]申请(专利权)人(译)	三星显示有限公司		
申请(专利权)人(译)	三星DISPLAY CO., LTD.		
当前申请(专利权)人(译)	三星DISPLAY CO., LTD.		
[标]发明人	SHIN HYEAE WEON LEE DONG WON SON YOUNG MOK		
发明人	SHIN, HYEAE-WEON LEE, DONG-WON SON, YOUNG-MOK		
IPC分类号	H01L27/32 H01L51/50		
CPC分类号	H01L27/3258 H01L27/3246 H01L51/5012 H01L51/5092 H01L51/5088 H01L51/5072 H01L51/5056 H01L51/0004 H01L51/5203 H01L51/5281 H01L51/56		
优先权	1020120108682 2012-09-28 KR		
其他公开文献	US9818811		
外部链接	Espacenet USPTO		

摘要(译)

公开了一种有机发光显示装置。有机发光显示装置包括基板，第一电极，像素限定层，第一疏水图案，至少一个电荷传输层，第二疏水图案，有机发光层和第二电极。衬底具有像素区域和围绕像素区域的非像素区域。第一电极，至少一个电荷传输层和有机发光层设置在像素区域中的基板上，而像素限定层，第一疏水图案和第二疏水图案设置在基板上的非像素区域。通过第一和第二疏水图案将一个像素的电荷传输层与另一个像素的电荷传输层隔开，以防止串扰现象。

